



---

# Güralp 5TB

## Operator's guide

Document Number: MAN-BHO-0005

Issue: F - November 2019

---

Designed and manufactured by  
Güralp Systems Limited  
3 Midas House, Calleva Park  
Aldermaston RG7 8EA  
England

---

# Table of Contents

---

<b>1 Preliminary Notes.....</b>	<b>4</b>
1.1 Proprietary Notice.....	4
1.2 Warnings, Cautions and Notes.....	4
1.3 Manuals and Software.....	4
<b>2 Introduction.....</b>	<b>5</b>
2.1 Digital borehole installations.....	6
2.2 The hole lock system.....	6
2.2.1 The single-jaw hole lock.....	6
<b>3 First encounters.....</b>	<b>8</b>
3.1 Unpacking and packing.....	8
3.2 Handling notes.....	8
3.3 Control units.....	9
3.3.1 The surface control unit.....	9
3.3.2 The hand-held control unit.....	10
3.3.2.1 Connections.....	10
3.3.2.2 Signal meter.....	11
3.3.2.3 Calibration and control.....	11
3.3.2.4 Banana plugs.....	11
3.3.3 The High-gain/low-gain break-out box.....	12
3.4 Adjusting DC offsets.....	13
3.5 Operating the hole lock.....	14
3.5.1 Engaging the hole lock.....	15
3.5.2 Disengaging the hole lock.....	15
3.5.3 Manual operation.....	15
<b>4 Installing the 5TB in a borehole.....</b>	<b>16</b>
4.1 Installing a sensor with hole lock unit.....	16
4.2 Installing a sensor using sand backfill.....	19
4.2.1 Procedure.....	20

---

---

4.3 Assembling the winch.....	24
4.4 Earthing a borehole sensor.....	28
4.4.1 Installations with AC power supplies.....	28
4.4.2 Installations with DC power supplies.....	30
4.4.3 External lightning protection.....	31
4.5 Down-hole orientation.....	32
4.5.1 Electronic compass.....	32
4.5.2 Orientation with a second instrument.....	34
4.5.3 Applying automatic rotation.....	34

---

<b>5 Calibration.....</b>	<b>36</b>
5.1 Absolute calibration.....	36
5.2 Relative calibration.....	36
5.3 Using a DM24 series digitizer for calibration.....	37

---

<b>6 Inside the 5TB.....</b>	<b>38</b>
6.1 The force transducer.....	39
6.2 Frequency response.....	39
6.2.1 The sensor transfer function.....	40

---

<b>7 Connector pin-outs.....</b>	<b>42</b>
----------------------------------	-----------

---

<b>8 Specifications.....</b>	<b>44</b>
------------------------------	-----------

---

<b>9 Revision history.....</b>	<b>45</b>
--------------------------------	-----------

---

---

# 1 Preliminary Notes

---

## 1.1 Proprietary Notice

The information in this document is proprietary to Güralp Systems Limited and may be copied or distributed for educational and academic purposes but may not be used commercially without permission.

Whilst every effort is made to ensure the accuracy, completeness and usefulness of the information in the document, neither Güralp Systems Limited nor any employee assumes responsibility or is liable for any incidental or consequential damages resulting from the use of this document.

---

## 1.2 Warnings, Cautions and Notes

Warnings, cautions and notes are displayed and defined as follows:



**Warning:** A black cross indicates a chance of injury or death if the warning is not heeded.



**Caution:** A yellow triangle indicates a chance of damage to or failure of the equipment if the caution is not heeded.



**Note:** A blue circle indicates indicates a procedural or advisory note.

---

## 1.3 Manuals and Software

All manuals and software referred to in this document are available from the Güralp Systems website: <https://www.guralp.com/> unless otherwise stated.

## 2 Introduction

The 5TB borehole accelerometer is a three-axis strong-motion force-feedback instrument in a cylindrical sonde. The sensor system is self-contained except for its 12 – 30 V power supply, which can be provided through the same cable as the analogue data. An internal DC–DC converter ensures that the sensor is completely isolated.

The sensor housing is manufactured from stainless steel, with double “O” rings throughout to ensure that the package is completely waterproof. A lifting hook on top of the sensor housing allows you to lower the sensor package into a borehole. To communicate with the sensor, a Güralp Systems 32-pin waterproof connector can be used (see the Appendices for pin-outs).

The 5T system combines low-noise components with high feedback loop gain to provide a linear, precision transducer with a very large dynamic range. In order to exploit the whole dynamic range two separate outputs are provided, with high and low gain. Nominally the high gain outputs are set to output a signal 10 times stronger than the low gain outputs. Both low and high gain outputs are differential, with a nominal impedance of 47  $\Omega$ ; a single ground line is used for all signals.

Full-scale low-gain sensitivity is available from 4.0  $g$  down to 0.1  $g$ . The most common configuration is for the 5T unit to output 5 V single-ended output for 1  $g$  ( $\approx 9.81 \text{ ms}^{-2}$ ) input acceleration. The standard frequency pass band is flat to acceleration from DC to 100 Hz (although other low pass corners from 50 Hz to 100 Hz can be ordered.) A high frequency option provides flat response from DC to 200 Hz.

Each seismometer is delivered with a detailed calibration sheet showing its serial number, measured frequency response in both the long period and the short period sections of the seismic spectrum, sensor DC calibration levels, and the transfer function in poles/zeros notation.

Optionally, you can use a Güralp Hand-held Control Unit (HCU) and breakout box to distribute power and calibration signals to the sensor, and to receive the signals it produces. The HCU can also adjust DC offsets during installation, if required. It is available in both hand-held and rack-mounted formats.

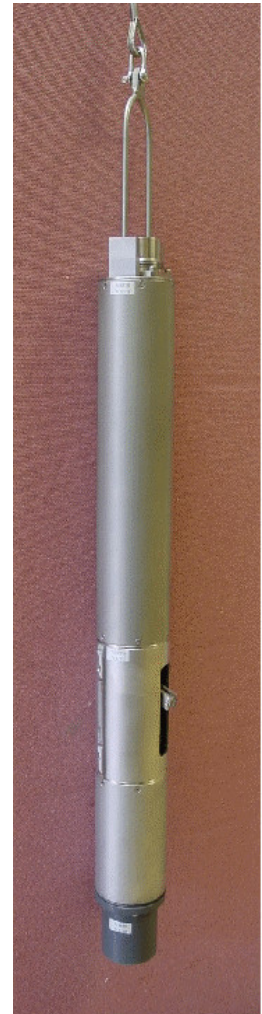

## 2.1 Digital borehole installations

The Güralp DM24 digitizer is available in a borehole sonde form. Connecting a Güralp borehole instrument to a down-hole digitizer allows you to construct a true digital borehole installation. This has several advantages over a traditional borehole set-up:

- Digital signals are not subject to attenuation as they travel up to the surface, so signals received are stronger and more reliable.
- Digitizing the data at source allows you to ensure that its origin can be reliably traced.
- The DM24 digitizer may also be combined with an Authentication Module within the borehole sonde, allowing you to generate cryptographically-signed data at the point of origin.

A digital borehole installation can be provided with RS232, RS422 or fibre-optic links to the surface, depending on the depth of the borehole.

When a down-hole digitizer is present, it takes the place of the strain relief unit in the borehole. The surface unit also takes a slightly different form, with a serial connector allowing you to attach a modem or other communications link. In this type of installation, instead of using the surface unit to pass control signals to the sensor, all functions can be accessed remotely *via* the digitizer.

If you prefer to install a stand-alone digitizer at the surface, it should be connected to the 19-pin *RECORDER* socket of the breakout box.

---

## 2.2 The hole lock system

The hole lock clamp unit in a 5TB instrument provides a stable platform for the sensor modules mounted above and below it. It is designed to maintain a positive pressure on the borehole casing over a prolonged period of time without attention, and to fix the sonde in place whilst avoiding transmitting any stresses.

Güralp Systems hole locks are constructed to order from accurate measurements of your borehole at the depth you wish to install the instrument.

In installations with sand backfill, or where the instrument rests on the bottom of the borehole, a hole lock may be unnecessary.

---

### 2.2.1 The single-jaw hole lock

The single jaw hole lock is the standard option for triaxial borehole instruments. It consists of an active clamp arm and a number of skids or studs on the sonde body. The arm is attached to a compression spring, which forces it to swing out from the sonde and wedge the body against the borehole wall. A serrated steel jaw at the end

of the arm provides maximum grip against the borehole casing. The skids or studs and the locking arm together form a multi-point clamp, which aligns the sonde body parallel to the axis of the borehole and holds it firmly in place so that it cannot twist or slip under the influence of ground vibrations.

There are several configurations of skids and studs which can provide a suitable clamp. Either

- the locking jaw pushes two steel skids against the side of the borehole, providing two line contacts;
- only the tips of the skids come into contact with the borehole, providing three point contacts;
- a single skid is combined with a pad to provide one line and one point contact; or
- three studs provide three point contacts.

Studs have the advantage of being smaller than skids, but the contact points are very close to each other. You should evaluate the various locking methods available to see which works best in your borehole.

The spring inside the lock provides around 30 kg of force at its locking position. A DC actuator retracts the arm into the body of the lock so that the sensor mechanism can be installed and removed. The actuator consists of a DC motor with a planetary reduction gear-head, which drives the nut of a ball lead screw through the helical drive gears. The thread of the lead screw is prevented from turning, and so moves linearly when the nut turns.

The motor has a power system separate from that of the sensor, and can be controlled from the surface using a hole lock control unit. Once the sonde is installed, the hole lock control unit may be removed. Without power, the hole lock will not be able to retract, and the sensor will be secured.

---

## 3 First encounters

---

### 3.1 Unpacking and packing

The 5TB seismometer is delivered in a single transportation case, which is specifically designed for the 5TB. This packaging should be reused whenever you need to transport the sensor. Please note any damage to the packaging when you receive the equipment, and unpack on a clean surface. The package should contain:

- the seismometer;
- a cable to join the sensors to the surface control box;
- the surface control box;
- the hole lock control unit, if ordered;
- a cable strain relief mechanism, if ordered;
- a Hand-held Control Unit (HCU) for monitoring sensor outputs and calibration, if ordered;
- an inclinometer monitor box;
- a calibration data sheet;
- this manual.

---

### 3.2 Handling notes

The 5TB is a sensitive instrument, and can be damaged if mishandled. It will not stand vertically upwards without support, and should not be operated until it has been securely installed in a borehole casing. If you are at all unsure about the handling or installation of the device, you should contact Güralp Systems for assistance.

- Avoid bumping or jolting any part of the sensor when handling or unpacking.
- Keep the sonde sections vertical wherever possible. Carry them by hand and store in a safe rack. Never drag or roll the sonde. If the sensor system topples over, you must inform Güralp Systems.
- Keep all the parts of the sensor system protected and clean so that they can be joined together securely. Store in the original packaging if possible.
- Do not kink or walk on the data cable (especially on rough surfaces such as gravel), nor allow it to bear the weight of the sensor.
- Do not connect the instrument to power sources except where instructed.



The 5TB is delivered as a single package, with its sections (including hole lock and magnetometer units, if ordered) already joined together. You should not need to disassemble it.

## 3.3 Control units

Once it has been installed, the 5TB is operated from the surface through various control units. All the 5TB's functions can be accessed through one or other unit. Most can be removed from the site once the instrument is ready for use.

Some of these control units are optional and may not have been supplied with your installation. Their functions can be duplicated either by applying voltages directly to control lines (see appendixes for pin-out information) or through a connected Güralp digitizer such as the DM24. The DM24 digitizer is able to pass commands to the instrument from an Enhanced Acquisition Module (EAM) or a computer running Güralp Systems' Scream! software, allowing you to access all of the instrument's functions remotely.

### 3.3.1 The surface control unit

This box should be installed in a surface enclosure, if you are not connecting the 5TB directly to a digitizer. It provides connections for the various elements of the sensor system.

If you are using a down-hole DM24 digitizer, it will be supplied with its own surface control unit, which differs from the one described here. See the DM24 operator's guide for more details.

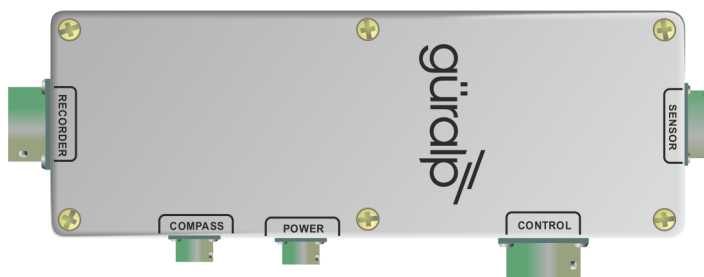

- The *SENSOR* connector is a 32-way military specification bayonet plug, and should be connected to the borehole instrument.
- The *RECORDER* connector is a 26-way military specification bayonet plug. This should be connected to an analogue data recorder or stand-alone digitizer. In systems using down-hole digitizers, this is replaced by a 10-way military specification bayonet serial connector for attaching to an Enhanced Acquisition Module (EAM), modem or other communications link.
- The *CONTROL* or *HCU* connector is a 26-way military specification bayonet plug intended for connecting to an external controller or Hand-held Control Unit, with the same pin out as the *RECORDER* connector.

- The *POWER/HOLELOCK* connector is a 10-way military specification bayonet plug, which should be connected to a source of 12 – 30 V DC power, for supplying to the borehole instrumentation.

This connector also provides pins for the hole lock mechanism. To manipulate the hole lock, you should connect it to a Hole-lock Control Unit. Because of the high voltages employed, the hole lock circuitry is entirely isolated from the rest of the electrical systems in the sensor and surface unit; it is not usual to power the sensor whilst using the hole lock.

- The *COMPASS* connector is 6-way military specification bayonet plug giving access to the optional electronic compass's signal and power lines. These are separate from the main instrument so that the compass and sensor can be operated separately. You may need to make up a suitable cable to operate the compass. See section 3.5 on page 14 and chapter 7 on page 42 for more details.

The borehole control unit is supplied with a 3 metre cable as standard. This can be extended up to 100 metres without compromising signal quality. The sensor uses amplifiers with high common mode rejection to ensure the signal to noise ratio is maintained over this distance. Individually shielded twisted-pair cabling *must* be used for the sensor outputs, control lines and power supply. If you need to make up a suitable cable, you should confirm the cable type with Güralp Systems.

---

### 3.3.2 The hand-held control unit

This portable control unit provides easy access to the seismometer's control commands, as well as displaying the output velocity and mass position (*i.e.* acceleration) on an analogue meter.

This HCU is based on that used for the Güralp 40T, so some of the markings are not relevant to the 5TB.

---

#### 3.3.2.1 Connections

The HCU provides

- two identical 26-pin connectors for attaching to the *HCU* or *RECORDER* connectors of the Surface Control Unit, and
- a 10-pin connector through which you can power the instrument, if desired. The power pins on this connector are directly connected to those on the sensor and *POWER/HOLELOCK* connectors of the Surface Control Unit. When using this alternative power connection, you should ensure you do not inadvertently connect two power supplies together.

### 3.3.2.2 Signal meter

The upper section of the HCU contains a simple voltmeter for monitoring various signals from the instrument.

- To monitor the low-gain acceleration outputs, switch the dial to *V, N/S* or *E/W LOW VEL* according to the component you want to monitor. Also use these settings to monitor the mass positions.
- To monitor the high-gain acceleration outputs, switch the dial to *V, N/S* or *E/W HIGH VEL*.
- The *V, N/S* or *E/W MASS POS* settings are not connected. To monitor the mass positions, you should use the *V, N/S* or *E/W LOW VEL* settings instead.
- You can set the range of the meter with the *RANGE* switch. When switched to 10 V, the meter ranges from  $-10$  to  $+10$  V (as marked.) When switched to 1 V, the range is  $-1$  to  $+1$  V.

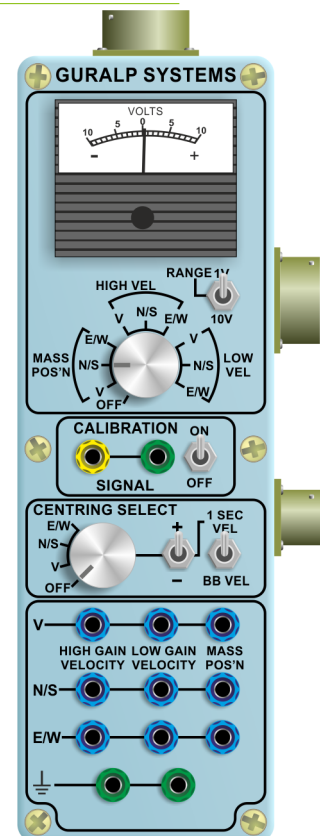

### 3.3.2.3 Calibration and control

You can calibrate a 5TB sensor through the HCU by connecting a signal generator across the yellow and green *CALIBRATION SIGNAL* inputs and setting the adjacent switch to *ON*. The sensor's response can now be monitored or recorded, and calibration calculations carried out.

The section of the HCU below the calibration lines controls the motors which adjust DC offsets within the instrument. You can use this section to trim DC offsets within the 5TB: see section 3.4 on page 13 for details.

### 3.3.2.4 Banana plugs

The remainder of the HCU provides useful connections for each of the signal lines from the instrument, for attaching to your own equipment as necessary.

### 3.3.3 The High-gain/low-gain break-out box

This box separates the high-gain and low-gain outputs of the instrument and routes them to two separate recorder connections, so that both outputs can be digitised at once, allowing the operator to take advantage of the full dynamic range of the instrument.

The six pins which carry the main differential outputs on the high-gain connector are coupled to the high-gain outputs from the instrument. The same six pins on the low-gain connector are coupled to the low-gain outputs from the instrument. With the exception of the power input lines, the other signals are connected as normal so that either recorder connection can be used alone. The power input lines are not connected, so as to avoid accidentally connecting the power outputs of two digitisers together, as described below.

You can connect two separate digitisers as shown:

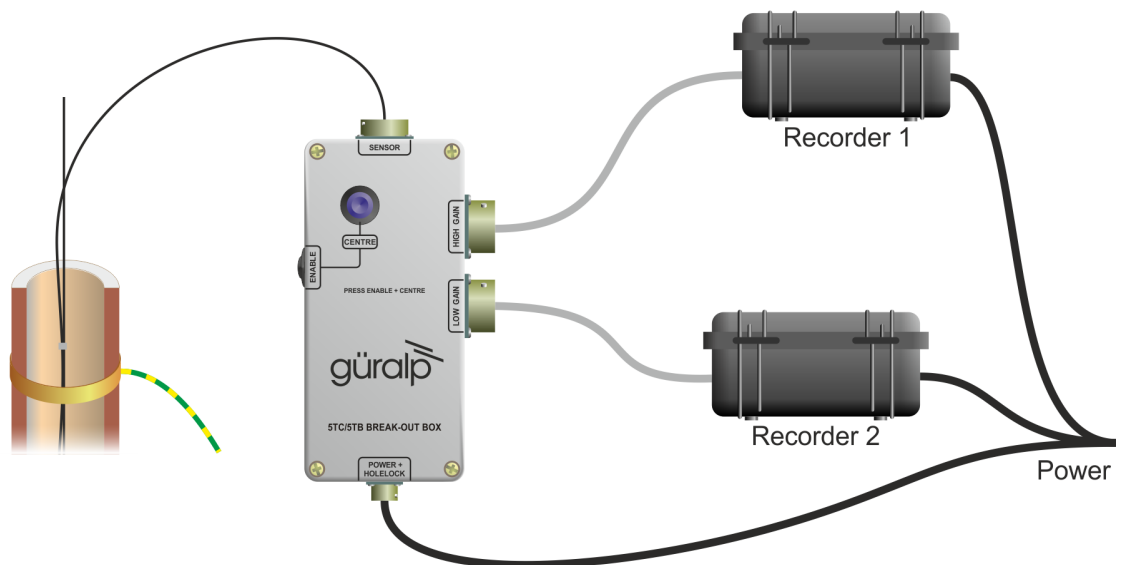

**Note:** Many digitisers have power outputs so that they can power sensors directly. To avoid shorting together the power outputs of the two digitisers, with consequent risk of damage or even fire, the relevant power input pins on the break-out box recorder connectors are not wired internally. Power for the instrument must be provided through the separate power input connector on the break-out box.

If you have a six-channel digitiser with a switched/monitored power output, such as a Güralp DM24S6EAM or Güralp Affinity, you can connect both of the instrument's outputs simultaneously and use the switched outlet for the instrument, as shown:

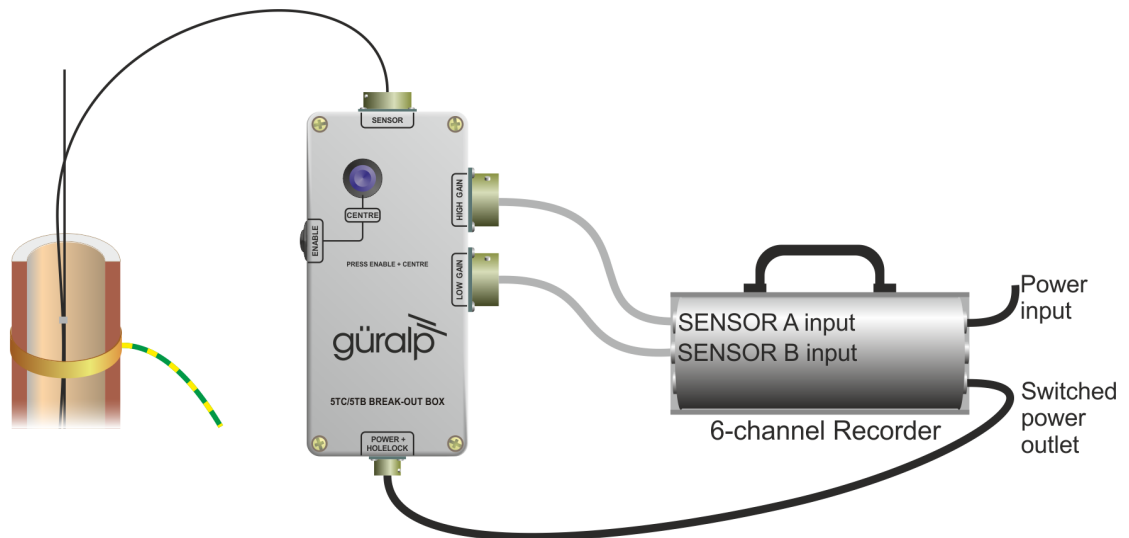

### 3.4 Adjusting DC offsets

Although the 5TB masses do not require centring, you may find that a component outputs a constant DC signal. Inside the 5TB, three motors drive potentiometers which can be used to zero these offsets. The offset circuitry is designed so that each component keeps its full dynamic range whatever the position of the potentiometer.

The easiest way to zero DC offsets is through the Hand-held Control Unit:

1. Select the component you want to zero from the *CENTRING SELECT* dial.
2. Switch the top dial to one of the *LOW VEL* settings, and set the *RANGE* to 1 V.
3. Switch the centring switch to *1 SEC VEL* to enable the motor lines.
4. Press the +/- switch towards - to zero a component from a positive value, or towards + to zero it from a negative value. The adjustment is quite slow, so be careful not to overshoot zero by pressing the switch for too long.
5. The DC offset is adequately nulled when the low-gain velocity output is within 5 mV of zero. Finer zeroing can be done within Scream! or your recording system.

If you prefer, you can zero the offsets manually. The *X*, *Y* and *Z Motor* lines from the sensor's output, together with the *Motor Return* line, are brought out on the *HCU* and *RECORDER* connectors of the sensor control unit. To operate a motor, apply 4 V between the *X*, *Y* or *Z* line and the *Return* line. Reverse the polarity to make the motor turn in the opposite direction. If you do not have a source of 4 V, you can use a 12 V source in series with a 47  $\Omega$  resistor.

### 3.5 Operating the hole lock

The hole lock, if fitted, can be extended and retracted using the hole lock control unit:

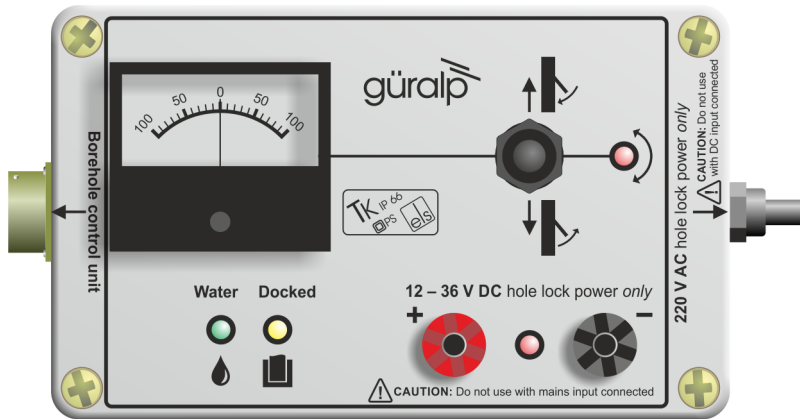

**Warning:** The hole lock may be using high-voltage mains (outlet) power. Observe suitable precautions.

1. Connect the hole lock control unit to the *HOLELOCK POWER* connector of the surface control unit, and to a mains power supply. *Alternatively*, connect a DC power supply (12 – 24 V) to the input terminals of the hole lock control unit.



**Warning:** Do not connect both DC and mains power at the same time.

The hole lock control unit supplied in regions with 220 V AC mains (outlet) power differs from that supplied for 110 V AC mains power. You should ensure that you provide the correct voltage to the hole lock control unit, otherwise damage may result to the sensor.

2. If you are supplying power to the sensor through another connector, ensure that it is switched off whilst you operate the hole lock.
3. If you are using a deep-borehole hole lock control unit, set the dial to zero.



### 3.5.1 Engaging the hole lock

To extend the jaw of the hole lock:

1. Hold the switch on the hole lock control unit in the *EXTEND JAW* or + position. If you are using a deep-borehole control unit, turn the dial until the built-in ammeter reads around 0.1 A.
  2. When the arm makes contact with the borehole casing, the current will drop slightly. Continue holding the switch in the *EXTEND JAW* position.
  3. When the lock arm reaches its fully extended position, the motor will automatically stop and the current will drop to 0 A. If using a deep-borehole unit, return the dial to zero.
  4. If the current has not dropped quite to zero after 30 – 40 seconds of operation, release the switch, wait a few seconds, and push it back to the *EXTEND JAW* position briefly. If the arm is not completely extended, you will see a surge of current. If the current remains constant, the jaw is at its maximum reach.
  5. Once the sensor is locked in place, it is recommended that you remove the hole lock power cable and control unit from the site. Without power, the hole lock will not be able to retract, and the sensor will be secure.
- 

### 3.5.2 Disengaging the hole lock

To retract the jaw of the hole lock:

1. Tension the load bearing cable, to take up any slack.
  2. Hold the switch on the hole lock control unit in the *RETRACT JAW* position or, on a deep-borehole unit, turn the dial until the built-in ammeter indicates 0.3 – 0.5 A. More current is drawn retracting the arm, because the motor is now working against the spring.
  3. When the lock arm reaches its fully retracted position, the motors will automatically stop and the current will drop to 0 A. If using a deep-borehole unit, return the dial to zero.
- 

### 3.5.3 Manual operation

If you prefer, you can operate the hole lock by applying voltages directly:

- To extend the jaw, connect the *Hole Lock Motor* pin on the sensor (or on the Surface Control Unit's *HCU* or *RECORDER* connectors) to a +12 V DC power source, and the *Hole Lock Motor Return* pin to 0 V.
  - To retract the jaw, reverse the polarity so that the *Hole Lock Motor Return* pin is at +12 V DC and the *Hole Lock Motor* pin is at 0 V.
-

---

## 4 Installing the 5TB in a borehole

Before installing any instrument in a borehole, it is recommended that you prepare the installation site so there is clear access all around the hole.

- Keep the borehole capped at all times except when inserting or removing the instrument, so that debris and tools do not accidentally fall in.
- Lay out the cables beside the borehole, or set up a cable drum nearby, so that they do not become tangled.
- Ensure the tripod is tall enough to hang the entire installation (sensor and strain relief unit or digitizer) from it, with the sensor off the ground.
- Use a winch with a depth gauge if possible, or measure out the cable beforehand.

Most installations are equipped with a strain relief unit, which consists of a metal arm that swings out from the load-bearing cable to wedge against the side of the borehole. This removes any strain in the load-bearing cable and prevents vibrations from the surface from being transmitted to the instrument. In installations with a down-hole digitizer, the strain relief arm is fitted to the base of the digitizer sonde; the phrase "strain relief unit" in the following instructions should be taken to refer to the digitizer's strain relief arm.

---

### 4.1 Installing a sensor with hole lock unit

1. Connect the signal cable to the connector on top of the sensor. Ensure that the "O"-rings inside the housing are clean, and tighten the knurled connector nut to its end stop.





2. If applicable, you should test the hole lock mechanism before installing the sensor. For safety reasons, the hole lock is normally supplied with the arm extended.

To test the mechanism, connect the signal cable to a Surface Control Unit and Hole-lock Control Unit, and attempt to retract the hole lock arm (see section 3.5 on page 14.) If this fails, you should contact Güralp Systems. Extend the arm once more.

3. Fix the main lifting cable to the shackle on top of the strain relief mechanism, and run the signal cable through the mechanism using the built-in clamps (without tightening them.) Do not allow the signal cable to bear any of the sensor's weight.



4. Attach the lifting loop to the sensor using four M5×16 screws (provided).



5. Join the loop to the bottom of the strain relief mechanism using the linking cable provided.
6. Using a small winch, hoist up the sensor package and strain relief mechanism until both are hanging by the lifting cable, with the strain relief mechanism extended. Tighten the cable clamps on the strain relief unit, allowing a little slack in the signal cable.



7. Fix the signal cable to the main lifting cable about 1 metre above the strain relief mechanism using a metal clamp (a nylon cable tie may be sufficient for shallow installations.) Leave a little slack in the signal cable between the clamp and the strain relief mechanism.
8. Position the assembly over the top of the borehole. Do not allow it to drag across the ground.
9. Lower the sonde so that its base is just level with the borehole mouth. If there is a depth gauge on the winch, set this to zero.
10. Continue to lower the sonde to a depth of about one metre, so that the instrument is still visible.
11. Extend the hole lock arm to check that it fits your borehole. The current drawn should dip slightly as the arm touches the casing, then drop to zero when it is fully extended. Check that the sonde is firmly anchored to the borehole casing by attempting to slacken the load bearing cable. If it remains taut, the sonde is still loose within the borehole. Do not proceed with installation in this case. Instead, you should either move the instrument to a narrower section of the borehole and try again, or contact Güralp Systems to fit a longer hole lock, quoting accurate measurements of your borehole.
12. Power up the instrument from a suitable power supply.
13. Check that the sensor is functioning correctly by connecting a meter or monitoring device to the sensor outputs. If the sensor fails to register ground movements, contact Güralp Systems.

14. Lock the sensor masses once more, tension the load bearing cable and retract the hole lock arm.
15. Gently lower the sensor to the required depth. At approximately 20-metre intervals, fix the signal cable to the load bearing cable using metal clamps (nylon cable ties every five metres may be sufficient for shallow installations). This will ensure that the signal cable does not become kinked or trapped within the borehole. Leave a little slack on the signal cable each time, so that it does not bear any weight. Too much slack, however, will cause the cable to scrape against the borehole casing.



16. Fix the sensor system into the borehole using the hole lock arm.

If you are installing a 5TB in a deep borehole, the weight of the sensor will stretch the load bearing cable slightly. Remember to allow for this when raising or lowering the cable in the following steps.
17. Use the winch to drag the assembly up within the borehole for a distance of 15 – 30 cm. This will ensure that the hole lock arm and the skids or studs on the sonde keep the sensor package vertical within the borehole. Do not drag too far, or you will damage the contact points.
18. Lower the load bearing cable by around 30 cm to engage the strain relief unit inside the borehole casing, and to provide some slack in the cables.
19. Clamp the load bearing cable to the top of the borehole.
20. Tie the lifting and signal cables together above the strain relief mechanism using tie wraps.
21. The sensor can now be centred ready for use: see section 3.4 on page 13.

---

## 4.2 Installing a sensor using sand backfill

Dry sand backfill is a convenient and effective way of installing a borehole or post-hole sensor in a time-stable environment. The presence of sand not only fixes the sensor in place at the bottom of the hole, but also reduces noise due to air convection.

The ideal type of sand to use is the fine, kiln-dried sand used for children's play sandpits. This is readily available in airtight bags, is thoroughly washed and clean, and will contain little sediment. (When dried out after wetting, sand containing foreign matter may solidify and “concrete” the sensor in position.) This sand is suitable for use in both dry and damp boreholes.

In the procedure outlined below, the sensor rests on a pad of sand around 300mm thick. This pad will absorb any residual moisture at the bottom of the borehole, and ensure that the surroundings of the instrument are kept dry.

After positioning the sensor, more sand is added to fill the space between it and the borehole casing, holding it firmly in place. The sand should reach within 30mm of the top of the instrument, but should not cover it. This way, the instrument can be more easily recovered when it requires maintenance or replacement. This is particularly important if the borehole is not completely dry, since moist sand does not flow well.

The following photographs show the steps involved in backfilling with sand:

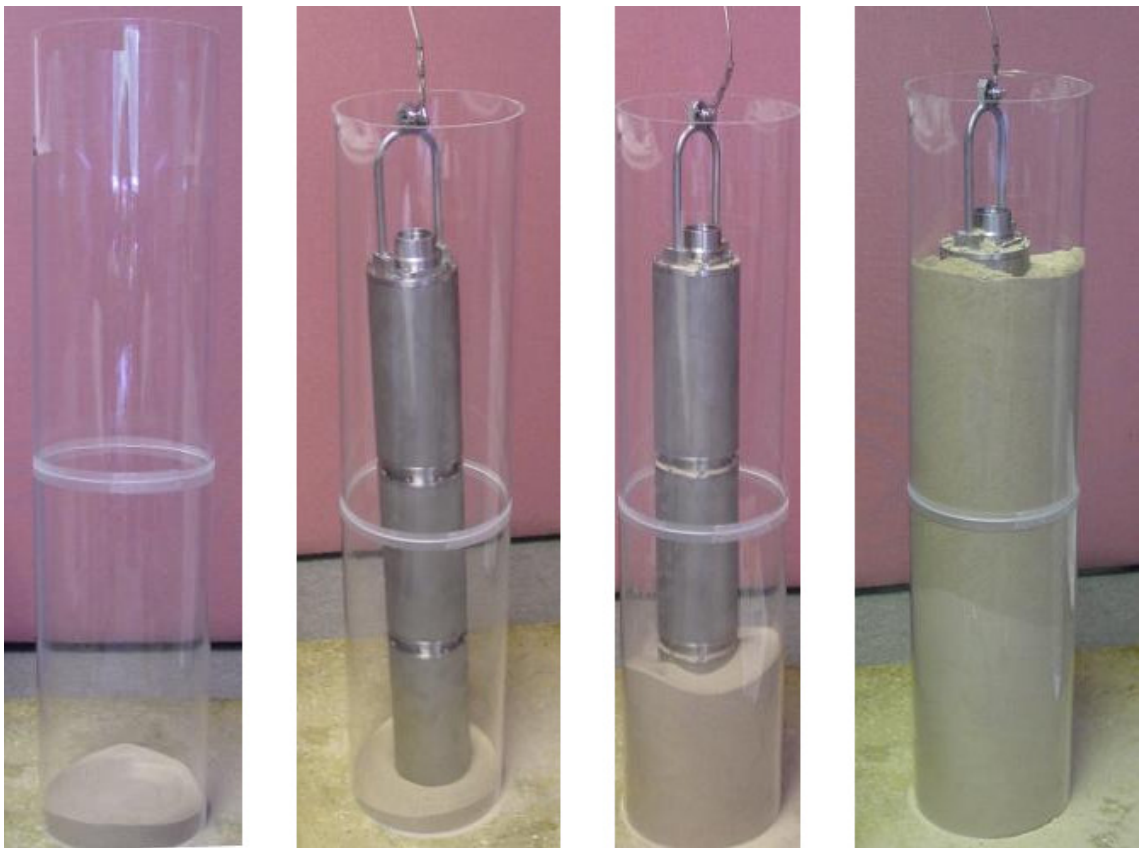

#### 4.2.1 Procedure

To install a sensor at the bottom of a borehole of known depth using sand backfilling:

1. Measure or calculate the physical volume of the unit which is to be installed in the borehole. (The volume of a cylinder  $v = \pi r^2 h$ .) Also, measure the internal diameter of the borehole.
2. Measure and pour in a sufficient quantity of sand to fill the borehole to a depth of around 300 mm.

3. Connect the signal cable to the connector on top of the sensor. Ensure that the "O"-rings inside the housing are clean, and tighten the knurled connector nut to its end stop.



4. Fix the main lifting cable to the shackle on top of the strain relief mechanism, and run the signal cable through the mechanism using the built-in clamps (without tightening them.) Do not allow the signal cable to bear any of the sensor's weight.



5. Attach the lifting loop to the sensor using four M5×16 screws (provided).



6. Join the loop to the bottom of the strain relief mechanism using the linking cable provided.
7. Hoist up the sensor package and strain relief mechanism until both are hanging by the lifting cable, with the strain relief mechanism extended. Tighten the cable clamps on the strain relief unit, allowing a little slack in the signal cable.



8. Fix the signal cable to the main lifting cable about one metre above the strain relief mechanism using a metal clamp (a nylon cable tie may be sufficient for shallow installations.) Leave a little slack in the signal cable between the clamp and the strain relief mechanism.
9. Position the assembly over the top of the borehole. Do not allow it to drag across the ground.

10. Lower the sensor so that its base is level with the borehole mouth. Set the depth gauge on the winch to zero.
11. Calculate how much lifting cable must be lowered into the borehole, taking into account the length of the sensor and the strain relief assembly or digitizer.

If you are installing a 5TB in a deep borehole, the weight of the sensor will stretch the load bearing cable slightly. Remember to allow for this when raising or lowering the sensor in the following steps, since allowing the instrument to strike the bottom of the borehole will damage it.

12. Begin lowering the sensor down the borehole, keeping track of the depth reached.
13. At approximately 20-metre intervals, fix the signal cable to the load bearing cable using metal clamps (nylon cable ties every five metres may be sufficient for shallow installations). This will ensure that the signal cable does not become kinked or trapped within the borehole. Leave a little slack on the signal cable each time, so that it does not bear any weight. Too much slack, however, will cause the cable to scrape against the borehole casing.



14. Whilst monitoring the depth of the sensor, carefully approach the sand layer at the bottom of the borehole. The lifting cable will go slack when the sensor makes contact with the sand.  
  
If the lifting cable goes slack before the sensor has reached the sand layer, it may have become caught on a bad joint or lip in the borehole; carefully raise and lower the instrument to free it.
15. When you have reached the bottom, use the winch to lift the package slightly, taking the slack off the cable. This ensures that the sensor is hanging vertically within the borehole, and is no longer in contact with the sand bed.
16. Calculate the volume of dry sand required to fill the gap between the sensor and the borehole liner to the level of the top of the sensor ( $v = \pi r^2 h$  using the internal radius of the borehole, less the volume of the instrument determined in step 1.)
17. Pour this sand into the borehole. If you can, check how much of the sensor is covered with sand. Do not overfill the hole.
18. Carefully slacken the load bearing cable. This will engage the locking arm of the strain relief mechanism and secure the installation within the borehole.

19. Without pulling or lifting the sensor, lightly shake the cables to remove any sand that may have fallen onto them or onto the strain relief mechanism.
20. Clamp the load bearing cable to the top of the borehole, and remove the winch.
21. The sensor can now be centred (see section 3.4 on page 13) ready for use.

---

## 4.3 Assembling the winch

If required, Güralp Systems can provide a winch suitable for installing a borehole sensor. The winch and tripod are supplied as a set of parts which you can assemble on site:



There are two sections for each leg of the tripod. The upper sections are pre-attached to the head of the tripod; the lower sections are supplied detached.

1. Slide the lower sections all the way into the head with the retaining tape loops facing outwards.



2. If you are working on a surface of *sand* or *soil*, rotate the feet so that the points face downwards (left). For *rock* or other hard surfaces, ensure the pads face downwards (right).





3. Erect the tripod above the borehole, and run the yellow retaining tape through the loops. Fasten together the ends of the tape.



4. The lifting cable is supplied with a loop at one end. Run this over one of the pulleys at the top of the tripod, so that the loop hangs down between the legs. If the loop is not provided, you can make one by untwisting three outer strands from the (7-core) cable, crossing the two sets, and pleating the three outside strands back around the remaining four in the opposite direction. Secure the loop with a cable clamp.
5. Run the sensor signal cable through the other pulley. Secure both cables in their pulleys by sliding the attached bolts into place.

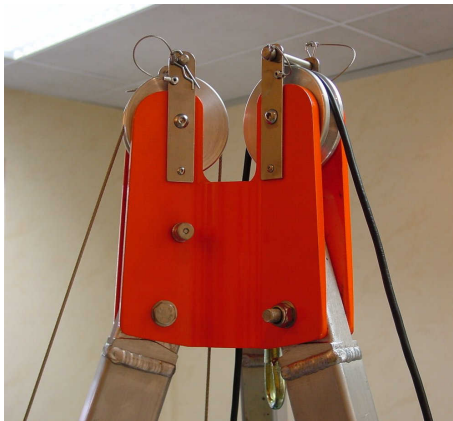

6. Extend each of the three legs in turn to the height you require, finishing at the leg with the winch attached.



7. Take the end of the load-bearing cable without the loop, and screw it to the axle inside the winch using a 4 mm hexagonal wrench (provided) as shown.

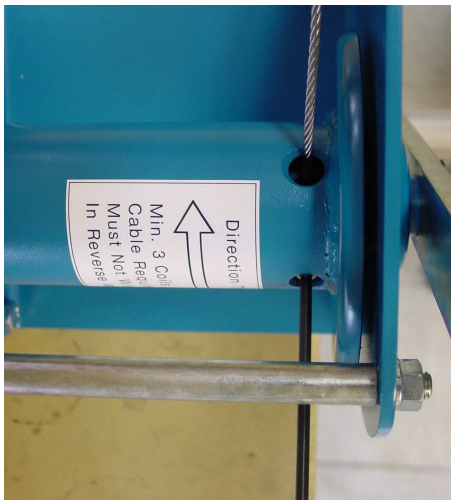

8. Attach the handle to the side of the winch *opposite* the ratchet mechanism, and fasten it in place with a collar, washer and screw, using the larger hexagonal wrench.

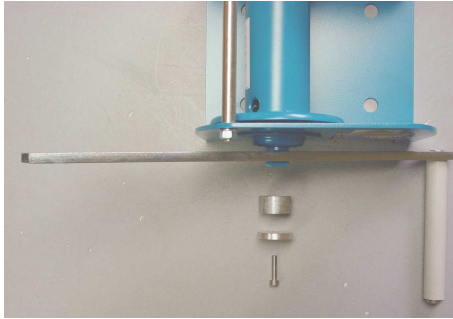

9. Wind the cable onto the winch by rotating the handle. Ensure that the cable builds up neatly across the drum. Continue winding until the loop on the other end is as high as you need it to install the equipment.



If the ratchet prevents you from winding the cable on, twist the metal boss in the *DOWN* direction to free the cable.

10. Remove the handle, and screw it onto the metal spool of the ratchet mechanism.



11. Hang the strain relief unit and instrument(s) from the loop at the other end of the cable. You are now ready to lower the assembly into the borehole as described above.

## 4.4 Earthing a borehole sensor

To achieve the best performance from any borehole instrument, you must make sure that the sensor electronics, its casing and the power supply share a common, local ground, and that all power and data lines are adequately protected against lightning and other transients.

This section describes techniques for grounding sensor equipment which have proved effective in many installations. However, local conditions are always paramount, and you should design your installation with these in mind. Any regulations in force at your chosen location must also be followed.

### 4.4.1 Installations with AC power supplies

If you are using mains (outlet) power, or some other AC power distribution system, we recommend installing a fully isolating transformer between it and the power supply for the instrument. This will allow full control of the local ground.

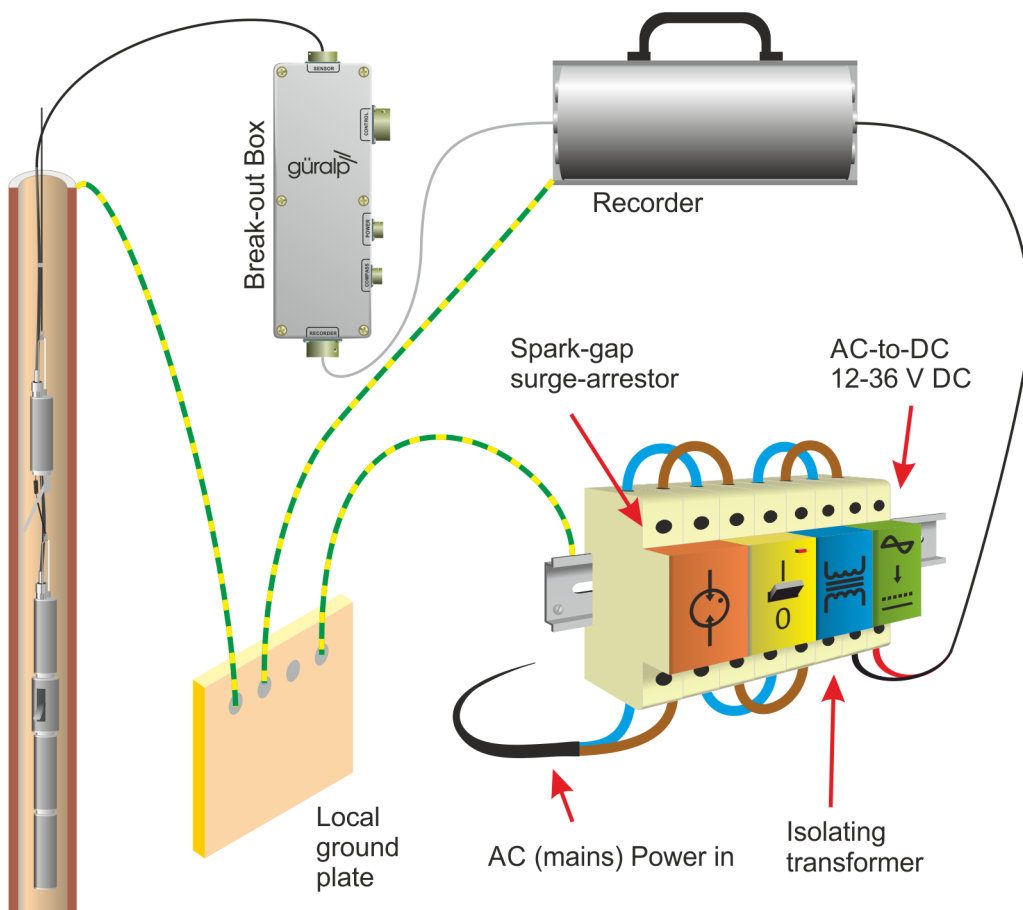

A spark-gap surge protector should also be installed on the mains side of the transformer, so that transient over-voltages are not transmitted across it. Suitable protectors are available off the shelf from several suppliers. On the sensor side,

surge protection is installed as standard within all new Güralp borehole sensors and control equipment. If your surface installation includes third party electronics, digitizers, etc., you may need to install additional protection where power and data lines enter the surface enclosure. Contact Güralp Systems if you are unsure.

Within the installation, a single ground point should be established, which is connected to a local ground plate. All earth lines for equipment in the installation, such as the casings of the transformers and of the sensor electronics, as well as the signal ground line from the sensor, should be connected to this plate.

The best local earth point in many installations is the borehole itself. For this to work, the borehole must have a conductive casing and be situated close (less than 30 metres) to the surface installation. In such an installation you need only connect a cable (green wire in the photograph below) from the local ground plate to the borehole casing. An earth strap can be used to ensure a good connection.

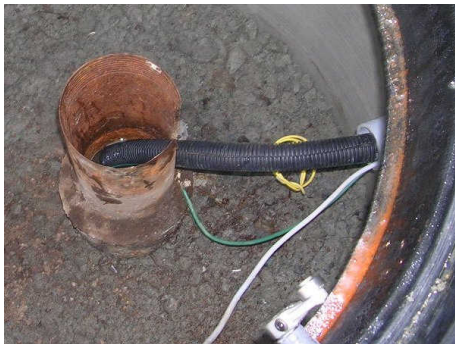

If the lower borehole is filled with salt water, the instrument will be adequately grounded without any further action. Fresh water is an inferior conductor.

In a dry or sand-filled borehole, or one with a non-conducting casing, you will need to ensure the sonde is grounded by some other means. The best option is often to attach the sensor housing to an earth line brought out to the surface and attached to a metal stake driven into the ground nearby.

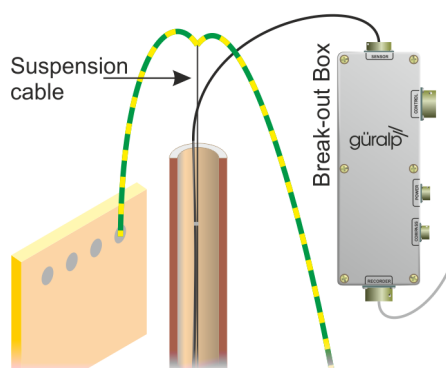

The sensor's load bearing cable is suitable for this purpose, provided it is secured to the sensor's lifting loop with a metallic clamp as shown below. This provides an additional firm contact between the sonde and the load-bearing cable. Installations with down-hole digitizers will need similar arrangements at the top and bottom of the digitizer module, or a separate cable for this purpose.

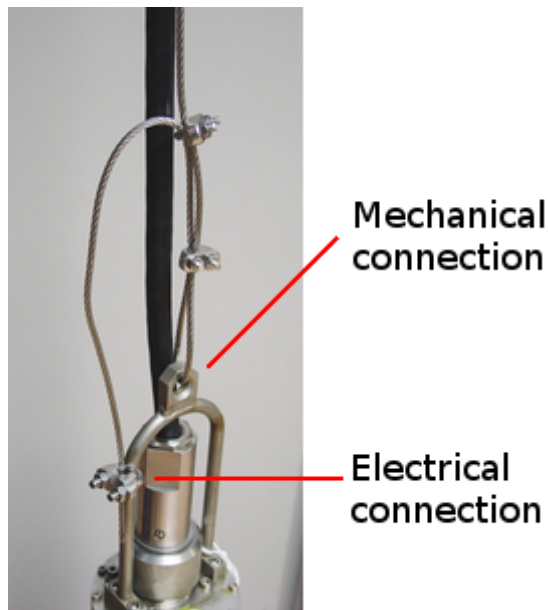

For boreholes with a metallic casing at the bottom and plastic above, we recommend connecting a cable between the sensor housing and the ground plate so that the lower borehole casing acts as the earthing point.

If there is a significant distance (more than thirty metres) between the borehole and the surface installation, the resistance of the earth cable may make it impractical to use the borehole as an earthing point. In these cases, you will have to connect the local ground plate to an earth stake near to the enclosure; any coupling between this sensor-local earth line and ground lines for other parts of the system must be minimized.

---

#### 4.4.2 Installations with DC power supplies

Güralp sensors require a 24 V DC power supply. In most cases, this is provided by an isolating DC/DC converter installed at the surface. This converter can be earthed to the local ground plate as above.

However, DC/DC converters contain sensitive electronics, which must be protected thoroughly. We recommend installing a full surge protection unit in addition to the spark gap protector. This protection is installed on the supply side of the isolator, so it must be earthed *separately* from the borehole installation. Otherwise, transients in the power supply will couple to the sensor.

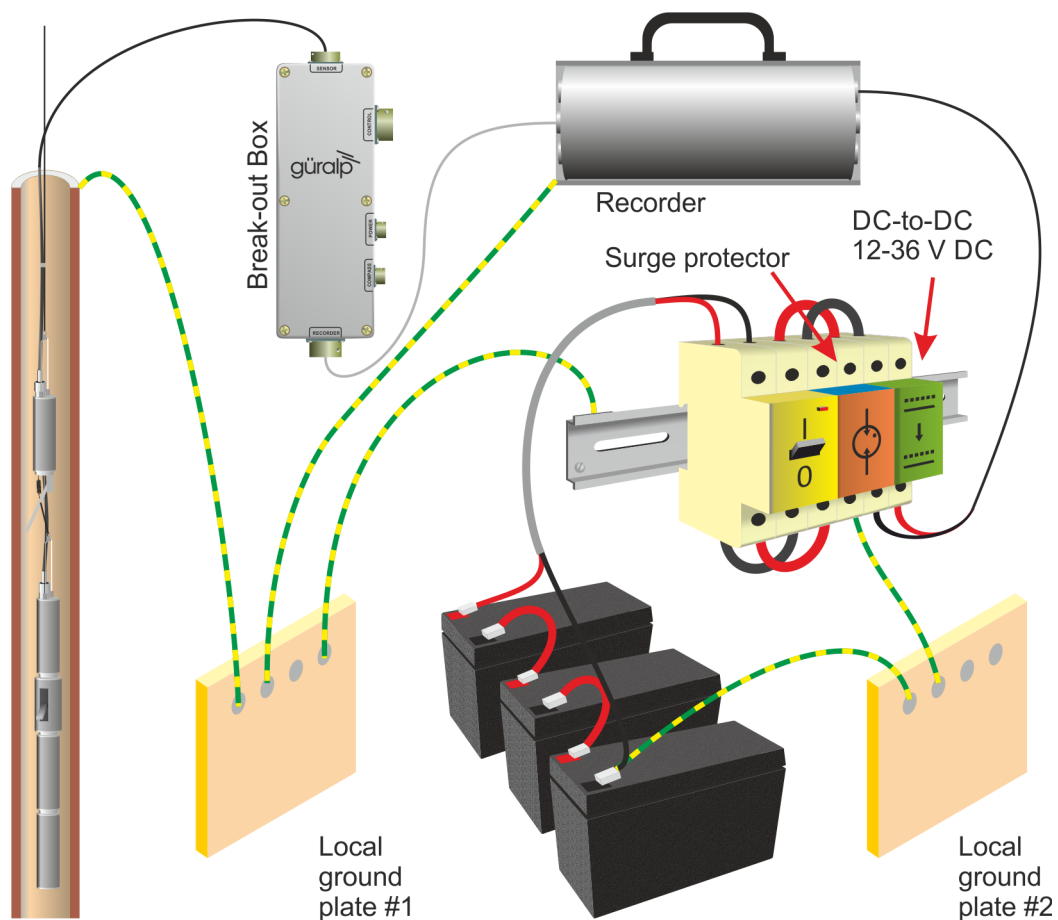

As with AC installations, if the borehole is more than around 30 metres from the surface enclosure, you will need to provide a second earthing point for the local ground plate.

DC power is most commonly available at self-contained installations with power supplied from batteries, solar panels, or a wind generator. In these cases, the power supply may already have protection from transients installed, in which case you may not need such comprehensive protection (although some form of protection is *always* necessary.)

#### 4.4.3 External lightning protection

The surface installation building, and if possible the borehole also, should be protected by lightning conductors. These should lead to ground well away from the borehole. As a rule of thumb, a lightning mast provides a “zone of protection” within a 45 ° cone the height of the mast.

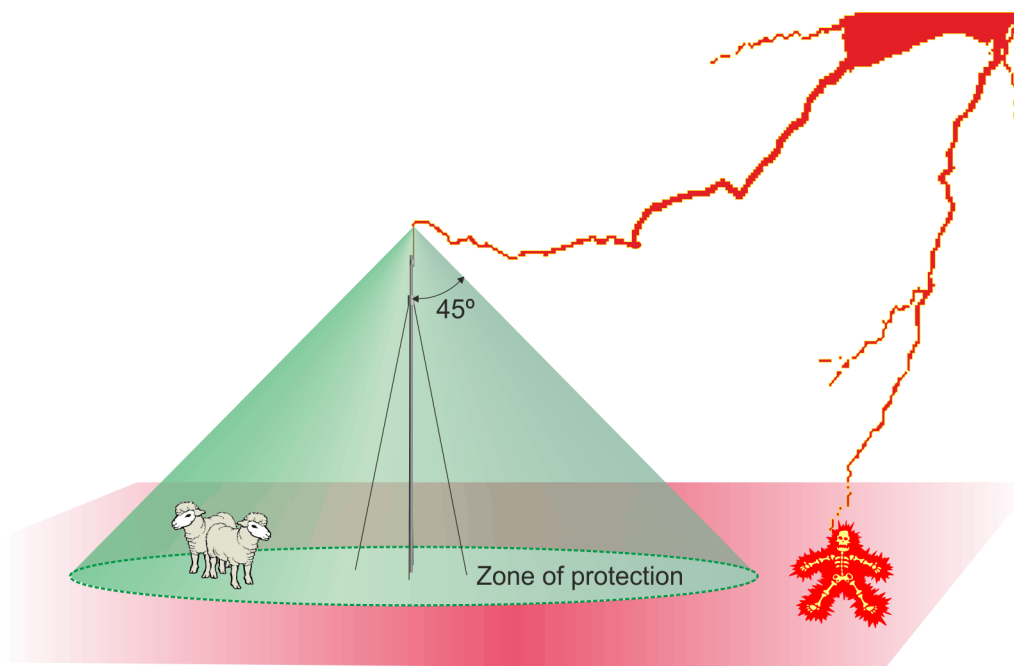

If you are using two earthing points, for example in the DC installation shown above, it may be convenient to connect the lightning conductor to the supply-side earthing point. In any case, the lightning earth must be well separated from the borehole (and its earth, if it needs one.)

## 4.5 Down-hole orientation

### 4.5.1 Electronic compass

An optional feature which can be installed with the 5TB is an electronic compass, which can be used to orient the sensor accurately within its borehole as long as the borehole casing is not made of a ferrous material. The compass consists of a three-axis magneto-resistive sensor module with conditioning and interface circuitry, mounted below the hole lock (if fitted) in a PVC housing:





Power is provided to the compass module through a DC–DC converter housed above the instrument. The module is fully isolated from the rest of the system, allowing the compass outputs to be measured independently. The compass can also be left switched off once the measurements are registered.

Outputs from all three axes of the compass are available, although only the two horizontal axes  $x$  and  $y$  are calibrated.

To use the compass:

1. Apply 12 – 24 V DC to the module through the surface interface box using the cable supplied.
2. Measure the output voltages for the  $X$  and  $Y$  axes (pins F and G respectively, referenced to signal ground at pin J).
3. You should allow at least twenty minutes for the readings to stabilise, as the compass circuitry will not produce accurate measurements until it has reached thermal equilibrium. Once the output from the compass is static, you can assume that thermal equilibrium has been reached.
4. Use the compass calibration plot provided with the 5T sensor's calibration documents to convert the voltages you obtain to a bearing. As an example, a compass installed with a 5TB sensor produced outputs of  $X = -0.708$  V and  $Y = +1.029$  V. From the calibration plot provided with that sensor:

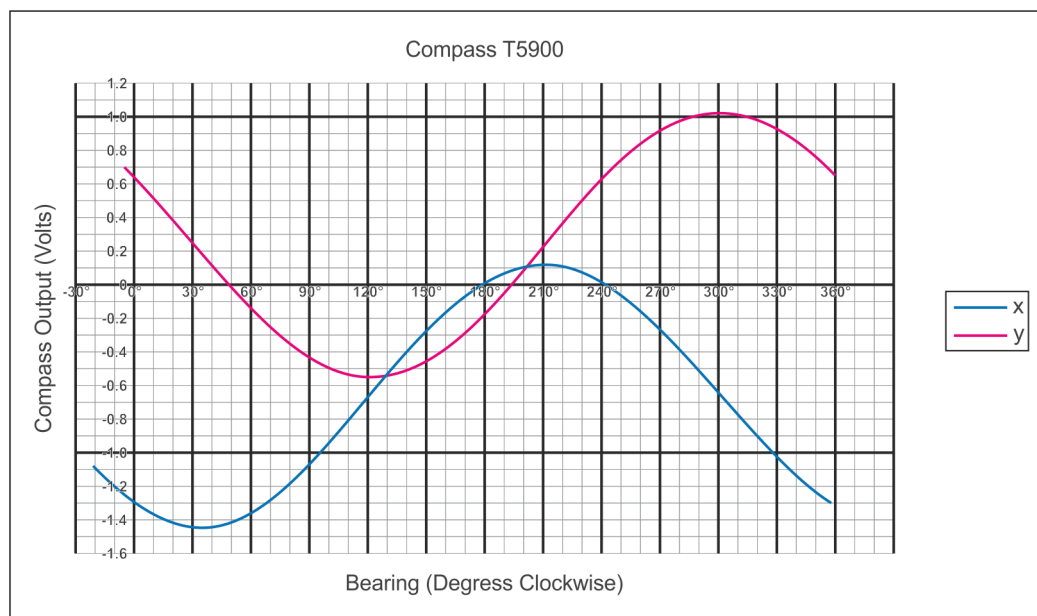

we see that the measured values of  $X$  and  $Y$  correspond to a compass bearing of  $305^\circ$ .

## 4.5.2 Orientation with a second instrument

If your 5TB is not equipped with a magnetometer, or you cannot use magnetic bearings at your site, you can measure its attitude by correlating signals with a second instrument at the surface. You can then rotate the signals from the 5TB algorithmically using *Scream!* or a Güralp DM24 digitizer.

A simple method for determining the orientation of a sensor package using the sensor's own horizontal component sensors has been used effectively by the Blacknest Seismological Centre, UK, with down-hole and surface equipment from Güralp Systems (AWE Report O 10/93, 1993.)

In this experiment, signals received by the N/S component of the reference sensor are correlated with those received at the N/S and E/W components of the sensor being studied, after different amounts of mathematical rotation. The highest correlation will occur when the N/S component of the reference sensor matches the rotated N/S component of the borehole sensor.

For information about this process please see "How do I determine sensor orientation?" in the Support→FAQs section of our web site.

Once you know the deviation of the borehole components from the compass points, you can instruct the digitizer to rotate the signals algorithmically.

## 4.5.3 Applying automatic rotation

You can configure a DM24 Mk3 digitizer to apply an automatic rotation to the digitized data and output streams representing ground motion on true North/South and East/West axes. This is done within the DSP to maximize the data quality.

To set up the rotation:

1. Open a terminal session with the digitizer. You can do this with a program such as `minicom` (for Linux) or `PuTTY` (for Microsoft Windows). Alternatively, you can access the digitizer's console through *Scream!* by right-clicking on its icon and selecting **Terminal...**

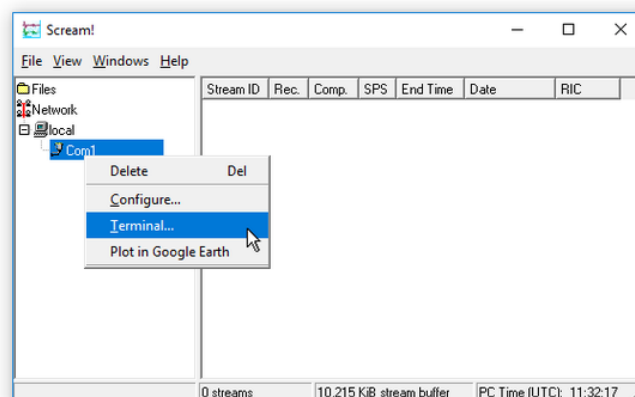

You should see an `ok` prompt, indicating that the digitizer is ready to receive commands.

2. Type

`0 rotation AZIMUTH`

where *rotation* is the angle of deviation from true North that you measured earlier, as a whole number of tenths of a degree. This is the same angle (with the same sign) as that given by the orientation program.

The `0` tells the digitizer to apply the rotation to instrument number 0 (the first, or only instrument.)

Thus in the example above, you would type `0 -903 AZIMUTH` to make the digitizer rotate signals by  $-90.3$  degrees.

3. Reboot the digitizer with the command `re-boot`.

4. Collect some more data (with the transformation active) and carry out another orientation calculation. The data from the down-hole instrument should now have a maximum coherence with the reference sensor at  $0^\circ$ . Check in particular that the sign of the rotation you have applied is correct.

## 5 Calibration

All Güralp instruments are supplied with comprehensive calibration documents, and it should not normally be necessary to calibrate them yourself. However, you may need to check that the response and output signal levels of the sensor are consistent with the values given in the calibration document.

### 5.1 Absolute calibration

The sensor's response (in  $V/ms^{-2}$ ) is measured at the production stage by tilting the sensor through  $90^\circ$  and measuring the acceleration due to gravity. Local  $g$  at the Güralp Systems production facility is known to an accuracy of five digits. In addition, sensors are subjected to the "wagon wheel" test, where they are slowly rotated about their sensitive axes.

The response of the sensor traces out a sinusoid over time, which is calibrated at the factory to range smoothly from  $1g$  to  $-1g$  without clipping.

### 5.2 Relative calibration

In addition to the response of the sensor, several other variables are calibrated at the production stage. Using these values, you can convert directly from voltage (or counts as measured in Scream!) to acceleration values and back. You can check any of these values by performing calibration experiments.

Güralp sensors and digitizers are calibrated as follows:

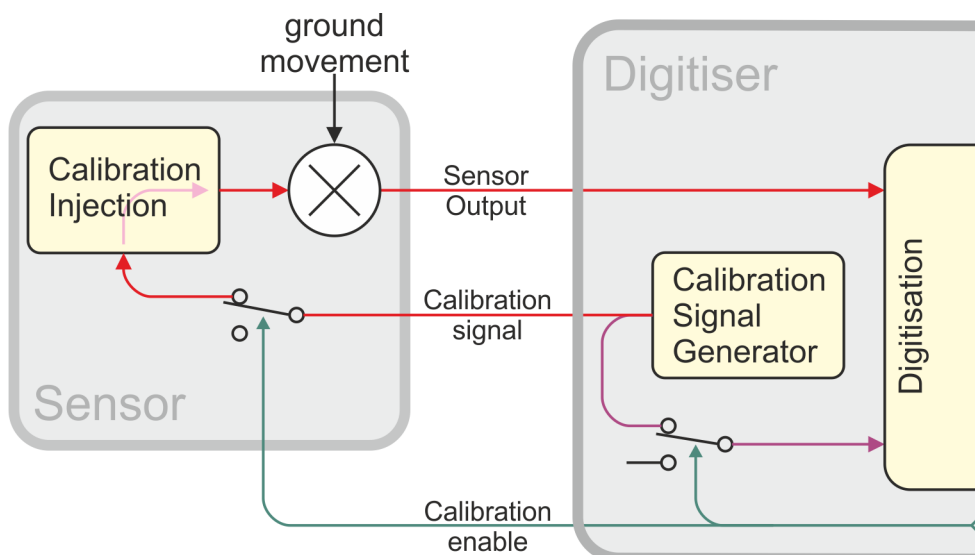

In this diagram a Güralp digitizer is being used to inject a calibration signal into the sensor. This can be either a sine wave or step function, depending on your requirements. As well as going into the sensor, the calibration signal is returned to

the digitizer on a dedicated channel. (The channel is available for other uses when the instrument is not being calibrated.) The calibration signals and sensor output all travel down the same cable from the sensor to an analogue input port on the digitizer.

The signal injected into the sensor gives rise to an *equivalent acceleration* (EA on the above diagram) which is added to the measured acceleration to provide the sensor output. Because the injection circuitry can be a source of noise, a *Calibration enable* line from the digitizer is provided which can disconnect the calibration circuit when it is not required. Depending on the factory settings, the *Calibration enable* line must be held either high (+5 to +10 V) or low during calibration: this is given on the sensor's calibration sheet.

The equivalent acceleration corresponding to 1 V of signal at the calibration input is measured at the factory, and can be found on the sensor calibration sheet. The calibration sheet for the digitizer documents the number of counts corresponding to 1 V of signal at each input port. The sensor transmits the signal differentially, over two separate lines, and the digitizer subtracts one from the other to improve the signal-to-noise ratio by increasing common mode rejection. As a result of this, the sensor output should be halved to give the true acceleration.

All sensors are tuned at the factory to produce 1 V of output for 1 V input on the calibration channel. For example, a sensor with an acceleration response of  $0.25 \text{ V/ms}^{-2}$  should produce 1 V output given a 1 V calibration signal, corresponding to  $1/0.25 = 4 \text{ ms}^{-2} = 0.408 g$  of equivalent acceleration.

---

## 5.3 Using a DM24 series digitizer for calibration

You can gain maximum functionality from the 5TB by combining it with Güralp Systems' DM24 series digitizers and computers running Scream! software. Both of these allow direct configuration and control of any attached Güralp instruments. For full information on how to use a DM24 series digitizer, please see its own documentation. If you are using a third-party digitizer, you can still calibrate the instrument as long as you activate the *Calibration enable* line correctly and supply the correct voltages.

The calibration process for a 5TB using a DM24 and Scream is described in detail on our website. See the "How do I calibrate using a broadband noise source?" article in the Support→FAQs section of our web site.

## 6 Inside the 5TB

The outer casing of the 5TB is constructed of hard-anodised aluminium with “O” rings throughout, ensuring a completely waterproof housing.

Inside, the masses of the vertical and horizontal components are attached to rigid frames with parallel leaf springs. The geometry of the spring spacing, together with the symmetrical design, ensures significant cross-axis rejection. Each sensor mass is centred between two capacitor plates, and moves in a true straight line, with no swinging motion. Feedback coils are attached either side of the sensor mass, forming a constant-flux force feedback transducer.

The vertical and horizontal sensors are identical in mechanical construction; the vertical sensor’s mass spring system is adjusted to compensate for gravity. They are mounted directly onto the base, with the sensor electronics fixed onto the rigid sensor frame. A single-row, 12-way surface mount R/A Molex connector joins each sensor to the main power supply circuit board.

The signal and feedback circuits inside the 5TB accelerometer are arranged according to the following diagram:

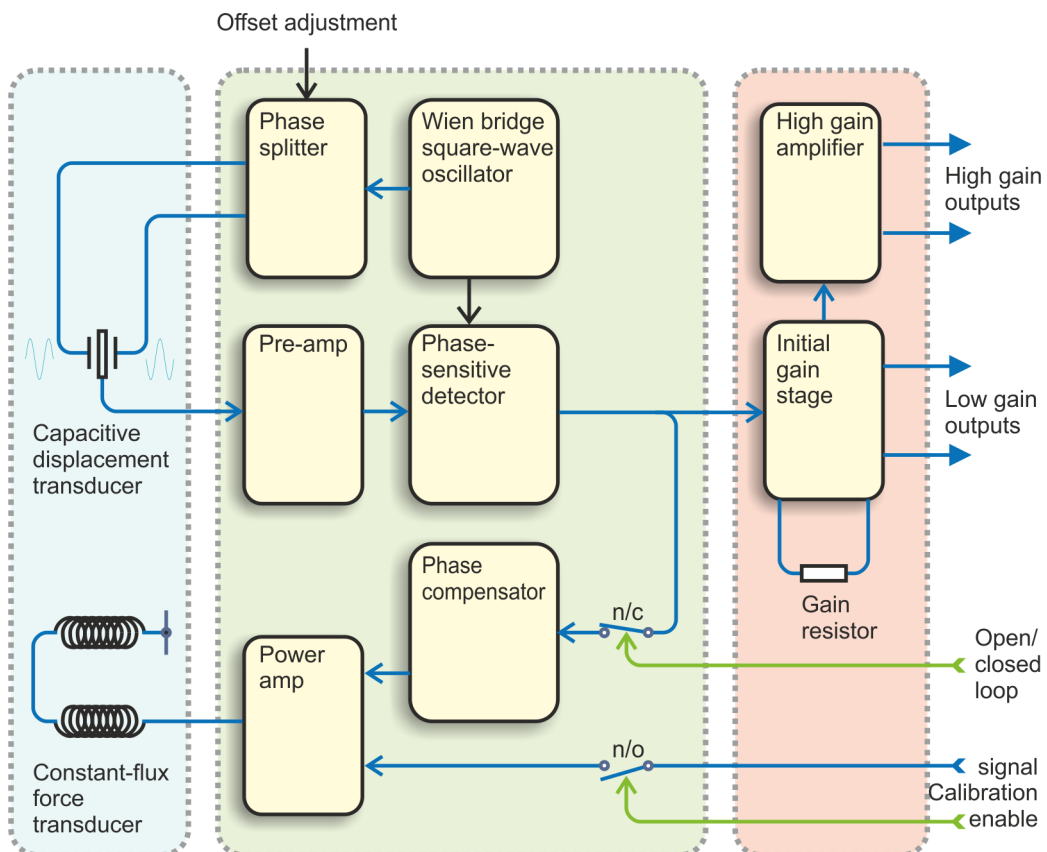

The mass and the capacitor plates are energised by a two-phase transformer driver, forming a differential capacitor. This acts as a capacitive transducer, whose signal is then demodulated with a phase-sensitive detector. The accelerometer feedback loop

is completed with a feedback loop compensator and a feedback force transducer power amp.

The differential output amplifier scales the output sensor sensitivity and a second stage amplifier can be configured (at the factory) either as a further cascaded gain stage or as a high-pass filter with unity gain.

### 6.1 The force transducer

The 5TB is a force feedback strong-motion accelerometer which uses a coil and magnet system to generate the restoring feedback force. Such accelerometers inherently depend on the production of a constant-strength field in the magnet gap. Although the high quality magnets used in the 5TB accelerometer are exceedingly stable under normal conditions, if the sensor is sited in an area where the background seismic noise is much higher than that of vaults built in seismically stable locations, the flux density may be affected by the external magnetic field generated by the feedback transducer coil.

In order to minimise non-linearities in the feedback force transducer, the 5TB uses a symmetrical system of two magnets and two force coils. Any increase in flux in one coil is cancelled by a corresponding decrease in flux in the other, thus eliminating any non-linearity due to lack of symmetry.

### 6.2 Frequency response

The frequency response of each component is provided as amplitude and phase plots.

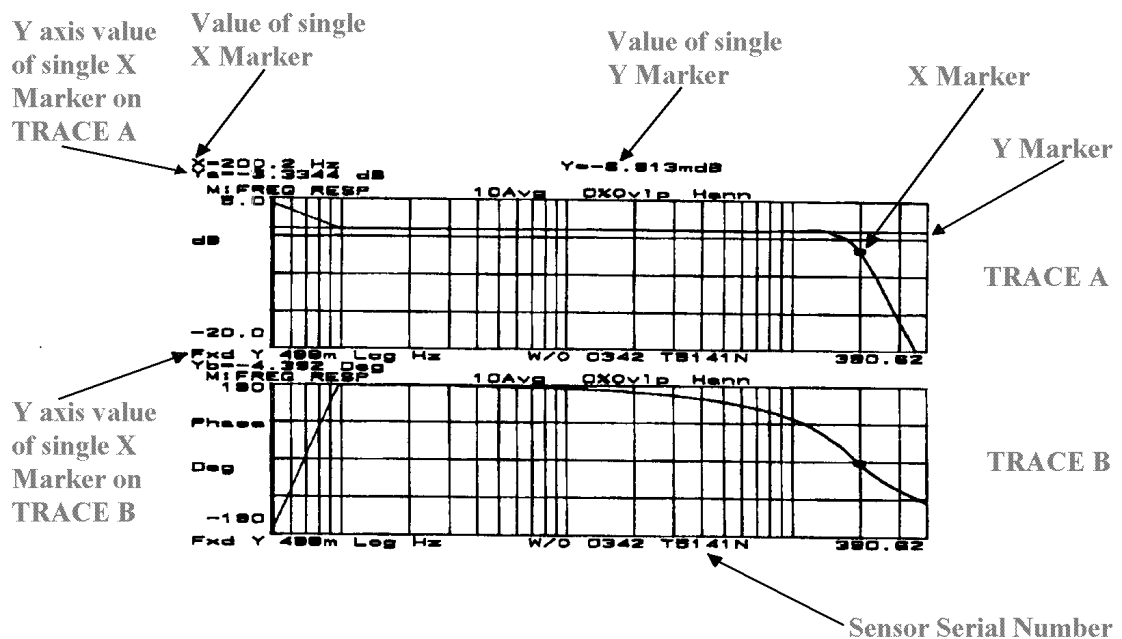

When testing the instrument to confirm that it meets its design specification, the range of frequencies used are concentrated over about 3 decades (*i.e.* 1000 : 1) of excitation frequencies. Consequently, the frequency plots of each component are provided in normalised form. Each plot marks the frequency cut-off value (often quoted as “-3dB” or “half-power” point).

Güralp Systems performs frequency response tests on every sensor at the time of manufacture. All records are archived for future reference.

### 6.2.1 The sensor transfer function

Most users of seismometers find it convenient to consider the sensor as a “black box”, which produces an output signal  $V$  from a measured input  $x$ . So long as the relationship between  $V$  and  $x$  is known, the details of the internal mechanics and electronics can be disregarded. This relationship, given in terms of the Laplace variable  $s$ , takes the form

$$\left[ \frac{V}{x} \right] (s) = G \cdot A \cdot H(s)$$

In this equation

- $G$  is the output sensitivity (gain constant) of the instrument. This relates the actual output to the desired input over the flat portion of the frequency response.
- $A$  is a constant which is evaluated so that  $A \cdot H(s)$  is dimensionless and has a value of 1 over the flat portion of the frequency response. In practice, it is possible to design a system transfer function with a very wide-range flat frequency response.

The normalising constant  $A$  is calculated at a normalising frequency value  $f_m = 1$  Hz, with  $s = j f_m$ , where  $j = \sqrt{-1}$ .

- $H(s)$  is the transfer function of the sensor, which can be expressed in factored form:

$$H(s) = \frac{\prod_{i=1,n} s - Z_i}{\prod_{j=1,m} s - P_j}$$

In this equation  $Z_n$  are the roots of the numerator polynomial, giving the zeros of the transfer function, and  $P_m$  are the roots of the denominator polynomial giving the poles of the transfer function.

In the calibration pack,  $G$  is the sensitivity given for each component on the first page, whilst the roots  $Z_n$  and  $P_m$ , together with the normalising factor  $A$ , are given in the *Poles and Zeros* table. The poles and zeros given are measured directly at Güralp



Systems' factory using a spectrum analyser. Transfer functions for the vertical and horizontal sensors may be provided separately.

## 7 Connector pin-outs

This table combines the pin-outs for all connectors on the 5TB borehole sensor and surface Control Unit:

Column (a): The single connector on the 5TB sensor, a 32-way military specification waterproof bayonet plug (02E-19-32P).

Column (b): The *SENSOR* connector on the breakout box, a 26-way military specification bayonet plug (02E-16-26P).

Column (c): The *RECORDER* and *HCU* connectors on the breakout box, each 26-way military specification bayonet plugs (02E-16-26P).

Column (d): The *POWER/HOLELOCK* connector on the breakout box, a 10-way military specification bayonet plug (02E-12-10P).

Column (e): The *COMPASS* connector on the breakout box, a 6-way military specification bayonet plug (02E-10-06P).

(a)	(b)	(c)	(d)	(e)	Function
A	A	A			Low gain acceleration +ve, vertical channel
B	B	B			Low gain acceleration -ve, vertical channel
C	C	C			Low gain acceleration +ve, N/S channel
D	D	D			Low gain acceleration -ve, N/S channel
E	E	E			Low gain acceleration +ve, E/W channel
F	F	F			Low gain acceleration -ve, E/W channel
H	H	H			High gain acceleration -ve, E/W channel
J	J		K		Hole lock motor return
K	K	K			High gain acceleration +ve, E/W channel
L	L		F		Hole lock motor
N	N	N			Sensor signal ground
P	P	P			Calibration signal
R	R	R			Calibration enable (all channels)
S	S	S			High gain acceleration -ve, vertical channel
T	T	T			High gain acceleration +ve, vertical channel
V	V	V			N/S motor (for offset zeroing)
W	W	W			E/W motor (for offset zeroing)
X	X	X			Vertical motor (for offset zeroing)
Y	Y	Y			Motor return (all channels)

(a)	(b)	(c)	(d)	(e)	Function
Z	Z	Z			High gain acceleration -ve, N/S channel
a	a	a			High gain acceleration +ve, N/S channel
b	b	b	A		Sensor supply 0 V
c	c	c	B		Sensor supply +12 V
d				E	Compass supply 0 V
e				D	Compass supply +12 V
f				A	X compass
g				B	Y compass
h				C	Z compass
j				F	Compass signal ground

## 8 Specifications

<b>Outputs and response</b>	Low gain output options	2g, 1g, 0.5g, 0.1g
	Corresponding high gain outputs	0.2g, 0.1g, 0.05g, 0.01g
	Dynamic range at 2 g	standard
	Dynamic range, 0.005 – 0.05 Hz	> 140 dB
	Dynamic range, 3 – 30 Hz	> 127 dB
	Standard frequency band	DC – 100 Hz (–3dB point)
	Optional low-pass corner	50, 100 or 200 Hz
<b>Calibration controls</b>	Linearity	0.1 % of full scale
	Cross-axis rejection	0.001g / g
	Open-loop response	pin on connector
	Closed-loop response	pin on connector
	Step function response	may be added to open- and closed-loop calibrations
<b>Physical</b>	External inputs	Sine-wave, step, or pseudo-random
	Lowest spurious resonance	450 Hz
	Operating temperature range	–20 to +70 °C
	Pressure jacket material	hard anodised aluminium
	Power / signal connector	Mil-spec connector on sensor housing (02E-14-19P)
	Borehole diameter	82 – 120 mm
	Weight	2270 g
<b>Power</b>	Current at 12 V DC	8 mA per axis

*Specifications are subject to change without notice. Please verify requirements at time of order.*

---

## 9 Revision history

2019-11-18		Refresh and optimise images
2019-02-14	F	Added details of High-gain/low-gain Break-out Box
2019-01-23	E	Updated to reflect new branding. Some images updated. Relative orientation and calibration with Scream sections replaced with references to web-site.
2008-08-18	D	Minor mistake corrected on connector pin-out table
2006-11-16	C	Added revision history
2004-12-23	B	Rewrite